

MIXING INFORMATION

Choosing The Right Mixer

These portable mixer selection guidelines will hold in most cases. "D" stands for Direct Drive, "G" for Gear Drive, and the numbers are the horsepower recommended. Mixing is in the range of 1/2 to 1 tank turnover per minute. For specific gravities of more than 1, multiply the SG times the recommended HP to obtain the new recommendation. For more vigorous agitation, choose the next size larger machine than the recommendation.

COMMON MATERIALS	VISCOSITY CPS.	TANK VOLUME - GALLONS - (LIQUID DEPTH = 1.0-1.5 TANK DIAMETER)								
		50	100	250	500	1000	2000	3000	5000	
Water	1.0	¼ D	¼ D	½ D	½ D	1D ¼ G	1¼ D ¼ G	2D ⅓ G	¾ G	
SAE 10 Oil	100	¼ D	½ D	½ D	1D ¼ G	2D ¼ G	⅓ G	¾ G	1G	
SAE 40 Oil	250	⅓ D	½ D	½ D ¼ G	1½ D ¼ G	⅓ G	¾ G	1½ G	2G	
Glucose	500	½ D	½ D ¼ G	¾ D ¼ G	2D ⅓ G	¾ G	1G	1½ G	2G	
Castor Oil	1,000	1D ¼ G	1½ D ¼ G	3D ½ G	¾ G	1G	1½ G	2G		
Molasses	2,500	⅓ G	½ G	¾ G	1G	1½ G	2G			
Honey	5,000	½ G	¾ G	1G	1½ G	2G				
Molten Glass	15,000	¾ G	1G	1½ G						
Mayonnaise	50,000	1½ G	2G							
Nylon Resin Melt	100,000	2G								

Mounting Suggestions

The illustrations show the ideal operating angles for portable clamp-mount mixers.

If tank diameter is approximately equal to liquid depth, use one Impeller. It should be 1 to 2 Impeller diameters from the bottom of the tank. For deep tanks, thick or thixotropic materials, 2 Impellers give best results.

Mixing shaft should be 10° to 20° off vertical and 10° to 20° off tank center line.

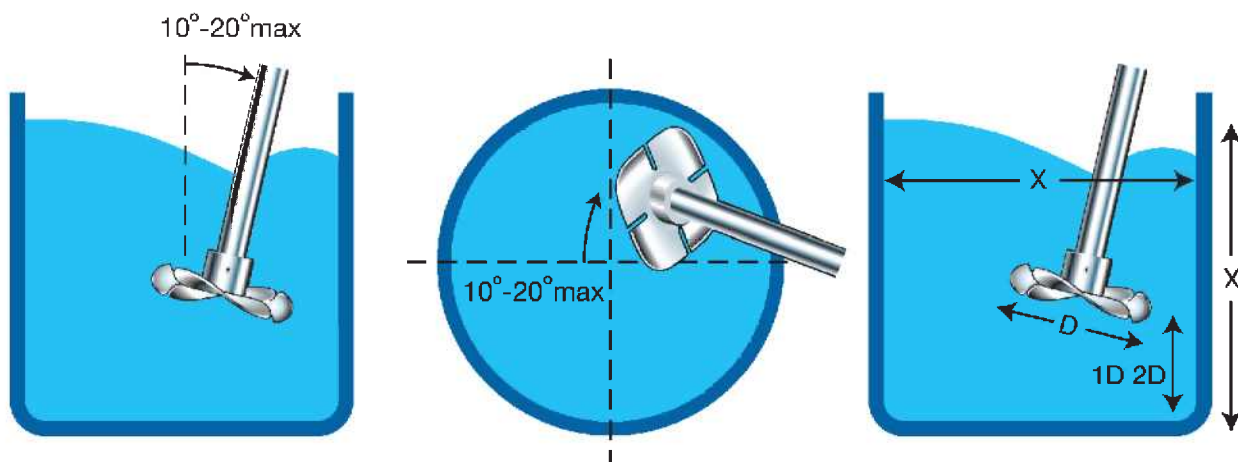

For a specific recommendation for your mixing or dispersing application, please contact sales@wmprocess.com or call 617-686-0843.